

BIKE-CHSX SIMPLE BIKE LANE CHICANE

Designed for cyclist safety near crossroads, the Bike-CHSX bike lane chicane makes an obstacle and creates a choking effect on the pathway, which together force cyclists to slow down. Made of powder-coated galvanized steel, chicanes are heavy duty, vandalism-proof and weatherproof. Every chicane is equipped with a locking system that keeps it either in closed position or opened position for maintenance or emergency situations.

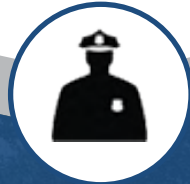

REDUCE CYCLISTS
SPEEDS



PIVOTS OPEN IN CASE
OF EMERGENCY



IMPROVE SAFETY FOR
ALL USERS

BIKE CHICANE AND BARRIER

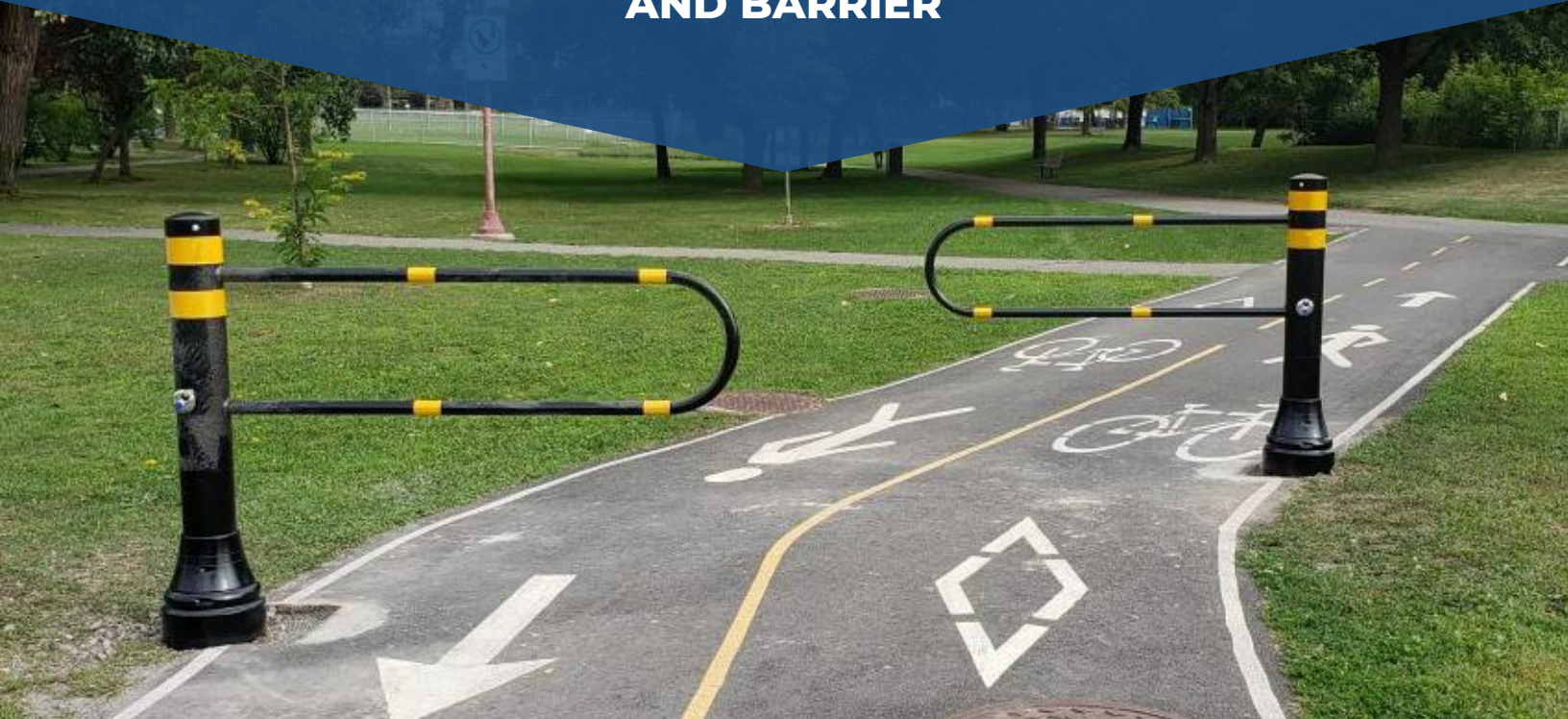



FEATURES OF THE CHSX SIMPLE BIKE LANE CHICANE



Visibility and safety on bike lanes

The reflective sheeting help locate the chicane in the dark. Installed near crossroads, the Bike-CHSX simple bike lane chicane for bike paths effectively helps reduce speed and improves safety of every user.

Recommended use

Bike path chicanes are in the first place intended to mark a potentially dangerous crossroad, then to make cyclists reduce their speed before actually crossing. The use of chicanes is recommended for all bike paths that are not directly on the side of the road. Besides, if the point is to block passage to cars and ATVs, it is recommended to install concrete bollards instead.

Recommended installation

First of all, it's important to leave a minimum clearance space of 3 m before the crossroad. This is to allow cyclists to get off their bike. Secondly, keep units about 3 m apart. This is to facilitate the passage of kid trailer equipped bikes. Finally, leave a 1 m clearance width on the bike path, to create the aforementioned choking effect which will force cyclists to slow down before entering the chicane.

To avoid cyclists bypassing the chicanes, it is advised to install units near a fence or any kind of barrier by a maximum of 0,5 m. If the fence is too far away from the bike path or is simply non-existent, double units (with two arms) are to be used instead. They will fill the gap and prevent any possible bypassing.

Installation

Two methods can be used to secure units to the ground. If a concrete slab is already made, only four (4) chemical anchorings of dia. 3/4" x 9,6" are needed for installation.

For installations on asphalt or lawn, a concrete cylinder (sonotube) reinforced with a buried base will be needed for maximum strength. Just dig a cylinder of 305 mm (12") of diameter and 1524 mm (60") deep, pour in 30 MPa concrete and insert the buried base while respecting direction.

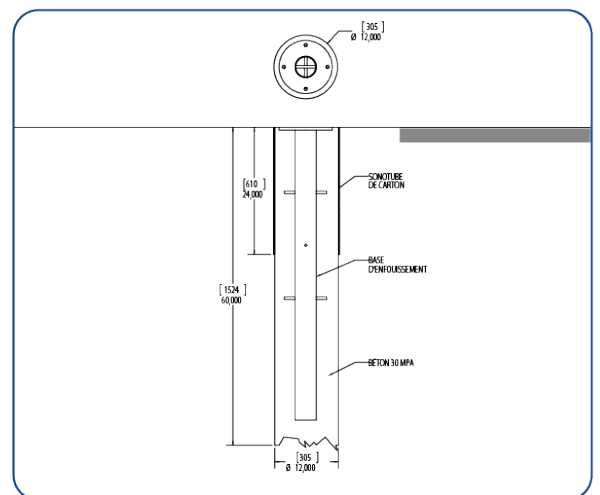
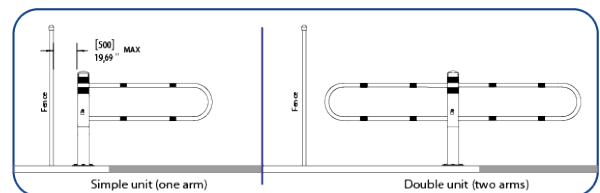
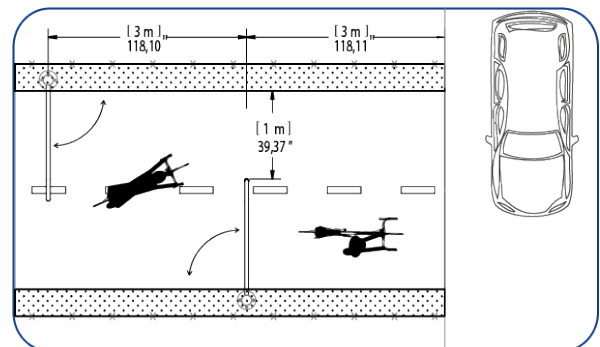



TECHNICAL SPECIFICATIONS OF THE CHSX SIMPLE BIKE LANE CHICANE

Features

Materials Structure: Powder coated Galvanized Steel
Sheeting: Diamond grade, type III

Standard colors Structure: Black, Textured Finish
Sheeting: Yellow or White

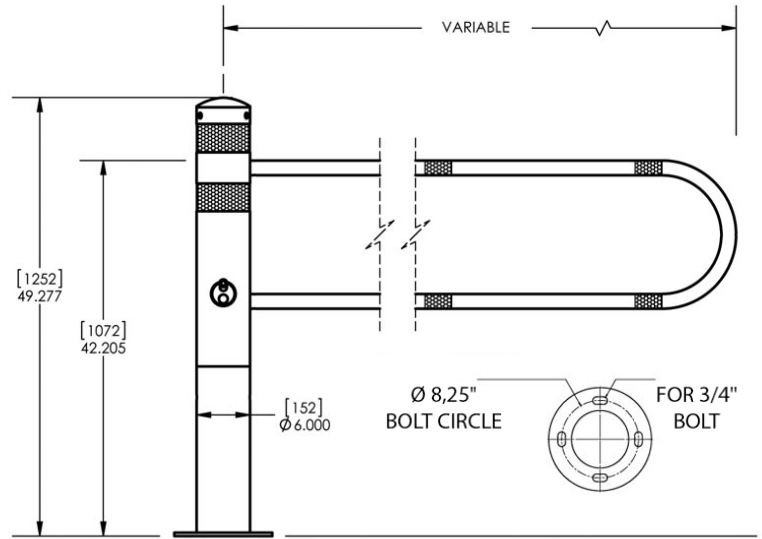
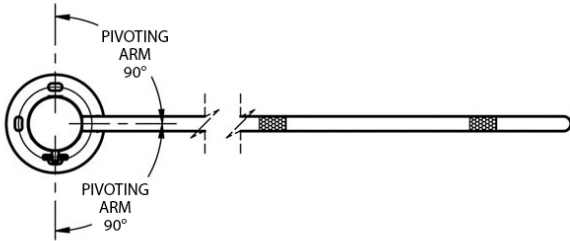

Product Number	Description	Box : Dimension - Weight	HSS Code
Assembly Kit			
#37112	1,6 m Simple Steel Swivel barrier for Bike path – Black painted – White or Yellow reflectives bands	Call for info	N/A
#37111	2,2 m Simple Steel Swivel barrier for Bike path – Black painted – White or Yellow reflectives bands	Call for info	N/A
#37113	3,2 m Simple Steel Swivel barrier for Bike path – Black painted – White or Yellow reflectives bands	Call for info	N/A
#38278	1,6 m Double Steel Swivel barrier for Bike path – Black painted – White or Yellow reflectives bands (one post with two arms)	Call for info	N/A
#38268	2,2 m Double Steel Swivel barrier for Bike path – Black painted – White or Yellow reflectives bands (one post with two arms)	Call for info	N/A
#38381	3,2 m Double Steel Swivel barrier for Bike path – Black painted – White or Yellow reflectives bands (one post with two arms)	Call for info	N/A
Options			
#30689	Decorative Base	Call for info	N/A
#32371	Steel Buried Base Depth 55 inches (1,4 m)	Call for info	N/A
#37596	Chemical Anchor Kit (4)	Call for info	N/A
#37160	Stainless Steel Padlock	Call for info	N/A

Included in kit : Two (2) years Limited Warranty against defects in workmanship and materials.



DECORATIVE BASE DIA.
150 X 280 MM #30689



STEEL BURIED BASE
DEPTH 1.4 M (55") #32371

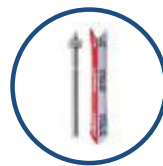

CHEMICAL ANCHOR DIA.
3/4" X 9,6" #37596 (4)



STAINLESS STEEL
PADLOCK #37160