

BLACK DEFLEX DELINEATOR – FLEXIBLE & DECORATIVE BOLLARD

This high-performance NTPEP tested delineator is a durable vertical traffic lane divider. Safer than a rigid delineator and clearly visible day and night, it has been designed for the safety of all road users. Lightweight and resilient, the 48" Deflex delineator is made of a treated polymer blend to withstand harsh weather and vehicle impacts, and keeps its shape after as many as 200 impacts at 55 mph/88 km/h. The 48" is the best height for being visible by all road users the Deflex 48 is a great way finding tool for the benefit of Vision Zero fatality.



MADE OF FLEXIBLE
POLYMER



EASY INSTALLATION ON
MULTIPLE SURFACES



DECORATIVE
VISUAL MARKER

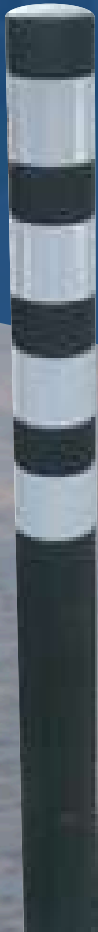

DEFLEX

FLEXIBLE DELINEATOR





FEATURES OF THE 48" DEFLEX FLEXIBLE



Monohull

No mechanical pieces for easy maintenance. Reduce debris if damaged.

Versatile installation of the delineator

This delineator can be installed permanently (bolted-in or glued), moved with a 7.25 kg (16 lb) weight base stabilizer or anchoring system for an easy in, easy out installation.

NTPEP

200 vehicle impacts tested at 55 mph/88 km/h

Durable and flexible bike path delineator

The DEFLEX delineator post is made of a flexible polymer and regains its original shape even after more than 200 impacts.

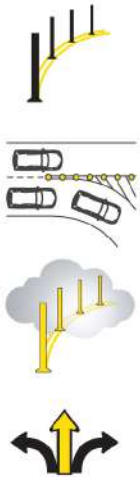

Increases safety in dangerous curves

Prevent drivers from passing over a solid line

Improve visibility in all weather conditions

Highlights channelizing geometry

Lane divider <i>with</i> concrete lane path divider		Lane divider <i>without</i> concrete lane path divider	
Straight lane	Curved lane	Straight lane	Curved lane
60' (20 METERS)	30' (10 M)	30' (10 M)	15' (5 M)
60' (20 M)	30' (10 M)	30' (10 M)	15' (5 M)
60' (20 M)	30' (10 M)	30' (10 M)	15' (5 M)

CENTER TO CENTER

CENTER TO CENTER



K-STYLE SLEEVE ANCHOR ADAPTER #BS114-K

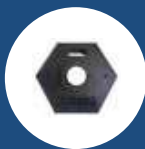

RUBBER STABILIZER 8.2KG / 18LB #33769



STANDARD INSTALLATION KIT #35199



ADHESIVE MASTIC FOR TEMPORARY INSTALLATION #MABC-DEFLEX



SLEEVE ANCHOR ADAPTER #BS114



TECHNICAL SPECIFICATIONS OF THE DEFLEX BLACK DEFLEX DELINEATOR - FLEXIBLE & DECORATIVE BOLLARD

Features	
Materials	Delineator: Flexible Polymer with anti-UV Sheeting: Diamond grade "prismatic", type IV
Features	Proven product since 2012 in harsh weather conditions and in temperatures between -20 and +35°C (-4 and +95°F).
Performance	360° flexibility and visibility. The Deflex delineator withstands 200 impacts at 70 km/h (45 mph) and regains its original shape, even after being crushed by the wheels of heavy trucks.
Standard Certifications	NCHRP-350 MTQ T-RV-10
Composition	Molded-in and non-detachable flexible cap. Four (4) embedded stripe sections protected from damage. 3M prismatic grade (type IV) reflective sheeting, flexible and visible on 360°. Many colors available, pigment integrated into the polymer material. UV protected.

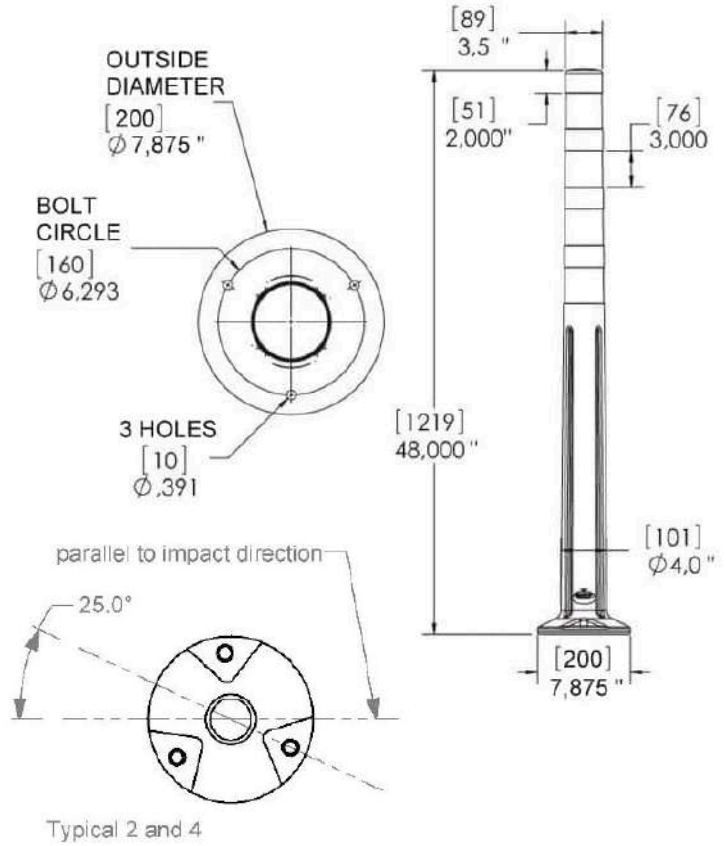

Product Number	Description	Box : Dimension - Weight	HSS Code
Assembly Kit			
#32416	Black Flexible delineator c/w 4 reflective White Diamond Grade Bands (4 lb)	Pallet 100 units : 44 x 50 x 80 in – 450 lbs	3926.90
#30819	Black Flexible delineator c/w 4 reflective Yellow Diamond Grade Bands (4 lb)	Pallet 100 units : 44 x 50 x 80 in – 450 lbs	3926.90
#33391	Black Flexible delineator c/w 4 reflective Orange Diamond Grade Bands (4 lb)	Pallet 100 units : 44 x 50 x 80 in – 450 lbs	3926.90
Options			
#33769	Hexagonal rubber base 8,2kg (18lb)	Pallet 50 units : 42 x 46 x 26 in – 1100 lbs	4017.00
#35199	Deflex ASPHALT Bolt-In Installation Kit Includes : 3x Screws, 3x Washers, 3x Inserts, 3x Plugs (0,66 lb)	Box 50 units : 11 x 17 x 4 in – 33 lbs	N/A
#39232	Epoxy Sika Anchorfix - 3001, 250ml (1,5lb) - Standard guns can be used - (Enough for 25 Deflex)	Box 50 units : 11 x 17 x 8 in – 75 lbs	N/A
#35198	Deflex CONCRETE Bolt-In Installation Kit Includes : 3x Concrete Screws, 3x Washers (0,4 lb)	Box 50 units : 42 x 46 x 16 in – 225 lbs	N/A
#33869	Ground spike for temporary installation of Deflex in soft ground (4,5 lb)	Box 50 units : 42 x 46 x 16 in – 225 lbs	N/A
#35543	BS114-K, Adapter for DEFLEX delineator (5 lb)	Box 50 units : 42 x 46 x 16 in – 225 lbs	N/A
#33069	BS-114, Sleeve Anchor Adapter for DEFLEX delineator (5 lb)	Box 50 units : 42 x 46 x 16 in – 225 lbs	N/A