

ROAD WORK - DEFLEX 48

48" FLEXIBLE ROAD WORK DELINEATOR

(FOR NARROW WORK ZONES & CITY USE)

This high-performance Deflex flexible delineator for road work is a durable marker to set boundaries on work zone. This delineator is clearly visible day and night and has been designed for the safety of the most vulnerable road users. Lightweight and resilient, the 48" Deflex delineator is made of a treated polymer blend to withstand harsh weather and vehicle impacts, it keeps its shape after as many as 200 impacts at 55 mph/88 km/h. 48" is the best height for being visible by all road users. The road work - Deflex 48 is a great traffic calming tool for the benefit of work zone safety.



MADE OF FLEXIBLE
POLYMER



EASY INSTALLATION ON
MULTIPLE SURFACES



PERFECT FOR
NARROW WORK ZONES

DEFLEX

FLEXIBLE DELINEATOR





FEATURES OF THE 48" DEFLEX FLEXIBLE ROAD WORK DELINEATOR



-  Perfect for narrow work zones
-  Quick and easy to deploy
-  Stable: resist the wind and truck drift.
-  High storage capacity
100 units in a pick-up truck
-  High visibility, day and night
-  Long lasting, affordable and economical



Stability means less maintenance after collisions

HOW TO INSTALL



Slide a rubber base

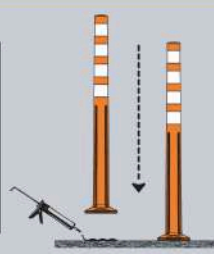

Use mastic or epoxy for temporary use

OPTIONS



#35739
With signage



Use a drop of epoxy, shield and bolt

SPEED LIMIT	Roadwork & Lane divider	
	Straight lane	Curved lane
20 MPH / 30 KM/H	15' (5 METERS)	10' (3 M)
25 MPH / 40 KM/H	15' (5 M)	10' (3 M)
30 MPH / 50 KM/H	30' (10 M)	15' (5 M)
35 MPH / 60 KM/H	30' (10 M)	15' (5 M)
40 MPH / 70 KM/H	30' (10 M)	15' (5 M)
50 MPH / 80 KM/H	45' (15 M)	25' (8 M)
55 MPH / 90 KM/H	45' (15 M)	25' (8 M)
60 MPH / 100 KM/H	60' (20 M)	30' (10 M)

CENTER TO CENTER



TECHNICAL SPECIFICATIONS OF THE 48" DEFLEX FLEXIBLE WORK ZONE DELINEATOR

Features

Materials	Delineator: Flexible Polymer with anti-UV Sheeting: Diamond grade "prismatic", type IV
Features	Proven product since 2012 in harsh weather conditions and in temperatures between -20 and +35°C (-4 and +95°F).
Performance	360° flexibility and visibility. The Deflex delineator withstands 200 impacts at 70 km/h (45 mph) and regains its original shape, even after being crushed by the wheels of heavy trucks.
Standard Certifications	NCHRP-350 MTQ T-RV-10 GUQ-1036
Composition	Molded-in and non-detachable flexible cap. Four (4) embedded stripe sections protected from damage. 3M prismatic grade (type IV) reflective sheeting, flexible and visible on 360°. Many colors available, pigment integrated into the polymer material. UV protected.

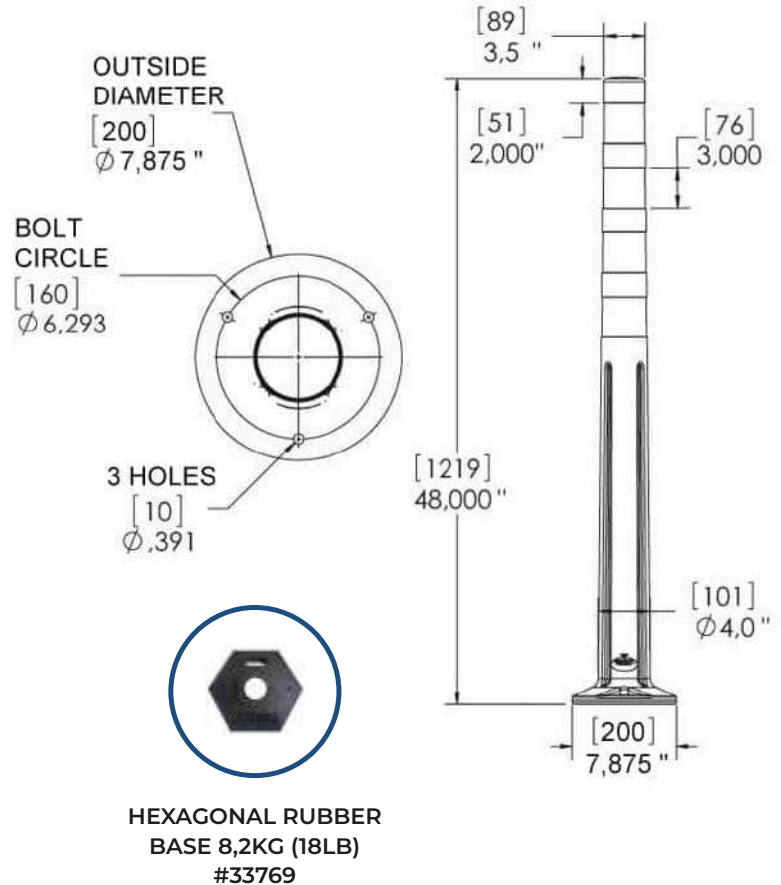

Product Number	Description	Box : Dimension - Weight	HSS Code
Assembly Kit			
#30820	Orange Flexible delineator with four (4) White Diamond Grade Reflective Bands	Pallet 100 units : 44 x 50 x 80 in – 450 lbs	3926.90
#33886	Orange Flexible delineator TRV-10 with five (5) White Diamond Grade Reflective Bands	Pallet 100 units : 44 x 50 x 80 in – 450 lbs	3926.90
#33391	Black Flexible delineator with four (4) Fluorescent Orange Diamond Grade Reflective Bands	Pallet 100 units : 44 x 50 x 80 in – 450 lbs	3926.90
Options			
#33769	Hexagonal rubber base 8,2kg (18lb)	Pallet 50 units : 42 x 46 x 26 in – 1100 lbs	4017.00
#35199	Deflex ASPHALT Bolt-In Installation Kit	Box 50 units : 11 x 17 x 4 in – 33 lbs	N/A
#32410	Adhesive Mastic 8" square c/w bolts & transfer plate	Box 50 units : 11 x 17 x 8 in – 75 lbs	N/A