

DEFLEX Delineators, Bollards and Chicanes

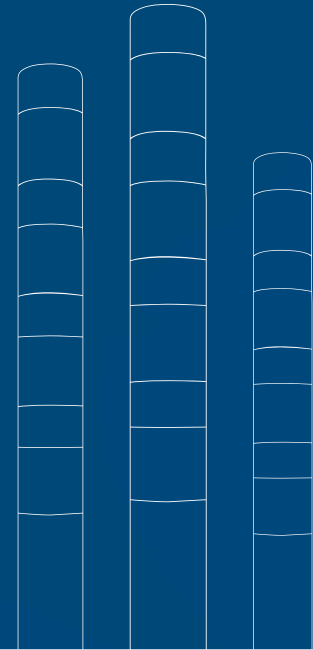

DEFLEX
Delineators

Protection
Traffic Control
Safety Zones
Speed Control
Crosswalk
School Zone

Decorative
& Steel Bollard

Safety Channelizing
Pedestrian Protection

Bike Path
Chicanes

Bicycle Path
Speed Control

DEFLEX

FLEXIBLE DELINEATOR

Visual Communication A color for each applications

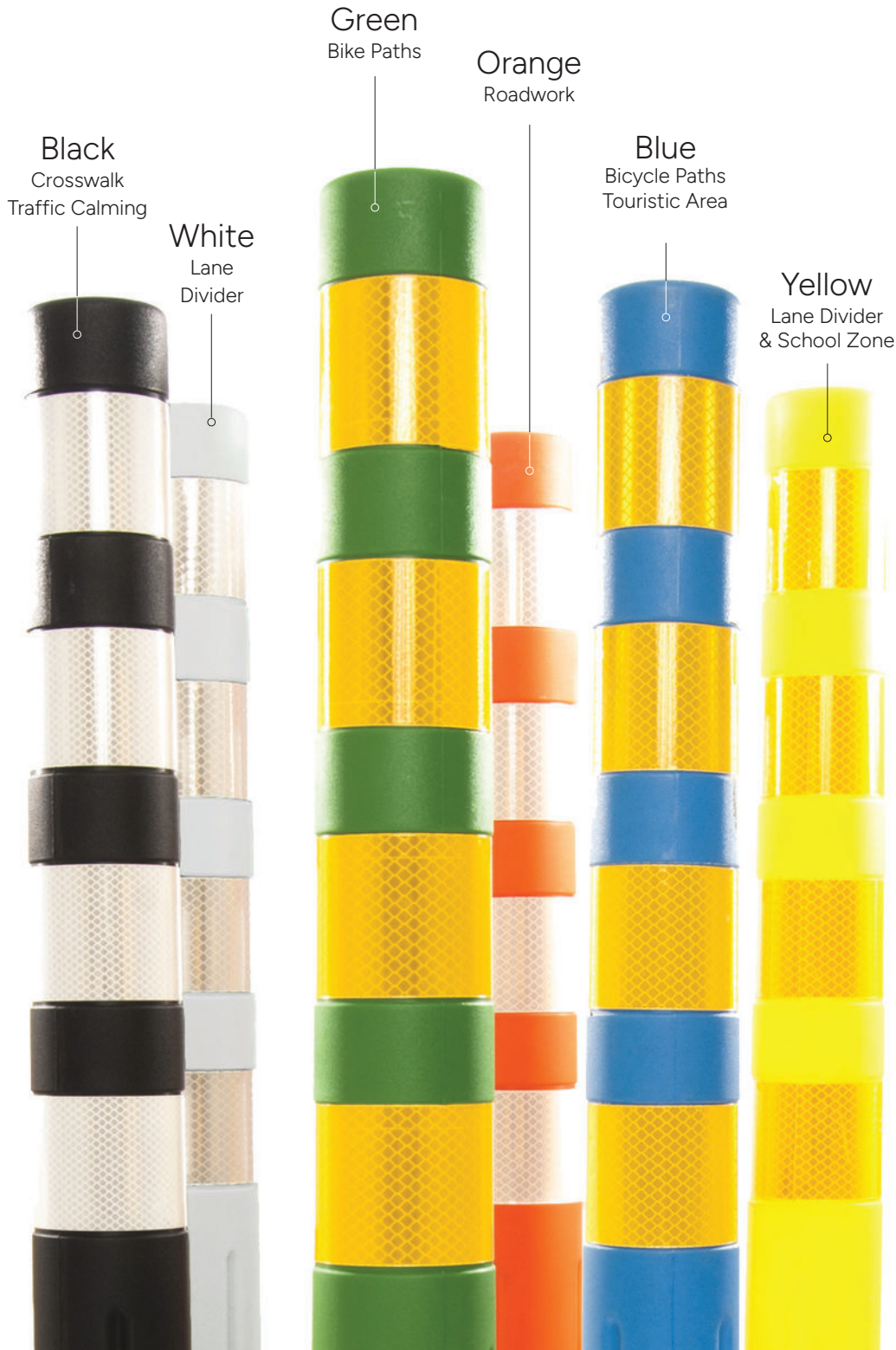

	Pages	Products
DEFLEX Delineators	6	Parking Lot Delineator
	7	Bike Lane Delineator
	8	Retractable Belt Delineator
	9	Road Works Delineators
	10	Lane Divided Road marking
	12	Installation Options
	13	How to order DEFLEX
Decorative & Steel Bollard	14	DECOFLEX, Flexible Decorative Bollard
	16	BOPS-MC 5.5" Deco Steel Bollard
	18	BOC 6" Carvel Bollard
	20	Bike-CHSX Simple Bike Lane Chicane

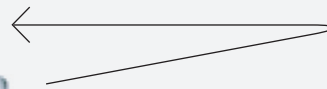
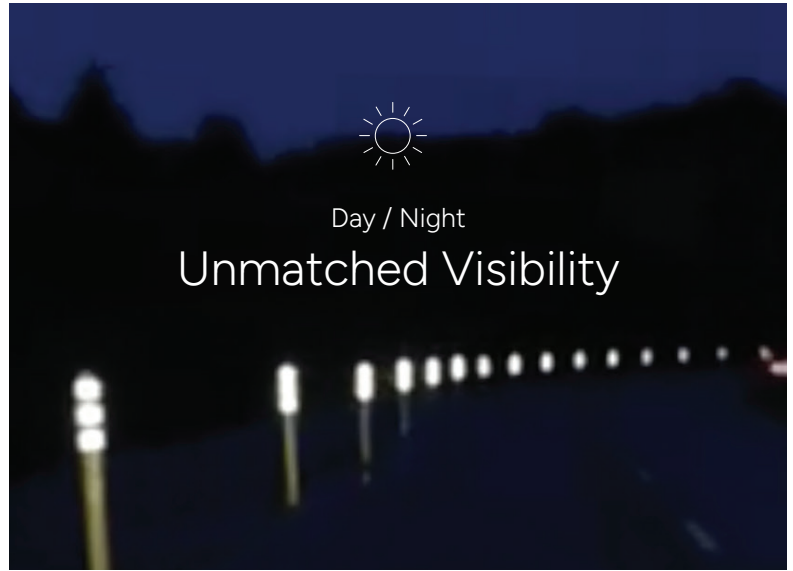

750 mm
29.5"



1220 mm
48"

View Impact tests

**WATCH
VIDEO**



Bounce Back
Keeps its original shape



**Flexible
Polymer**

Withstands more than 200 impacts. Minimizes damage to vehicle and safe for cyclists in case of impact.

City's Best Traffic Calming Device



360°

Visible and flexible from all angles. No orientation required upon installation.

Height 48"

The distance between a truck driver's eyes and his headlights requires a high visual marker. **At a height of 48" - 1200mm**, the Deflex provides maximum safety with proper visibility for all types of vehicles.

With the Deflex, road markings are vertically extended improving road channelizing efficiency, especially in congested traffic. Cyclists and pedestrians feel safer from motorists with a higher channelizer.

UV Protected and Solid Color

A protective additive incorporated in the polymer prevents color from fast fading.

Reflective Stripes

The embedded reflective stripes provide a longer life and improve safety expectancy upon multiple impacts.

This High level of reflectivity (ASTM Type IV) and its diameter of 3.25" (83 mm) increases visibility at night.

NTPEP TESTED

200 vehicle impacts tested

NCHRP -350

Standard Certification

Monohull (One Piece)

No mechanical parts means easy maintenance. Less components on the roads if damaged.

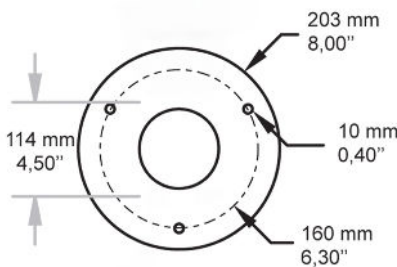

Parking Lot Delineator

Our DEFLEX flexible parking lot delineator highlights parking areas with visual markings to improve management and driver experience. Different colors help identify reserved parking spaces for the disabled, families, pregnant women and employees, among others.

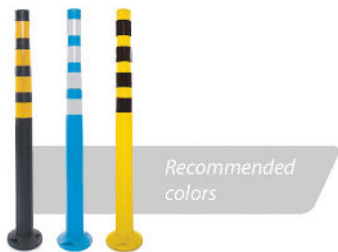

Made of flexible Polymer



Easy Installation



Seasonal Installation



Increase Safety



Bike Lane Delineator

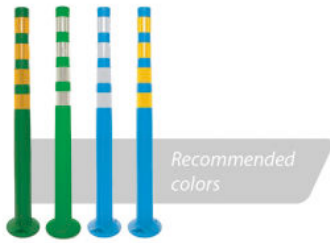

This high-performance Deflex flexible delineator for bike lanes is a durable marker to set boundaries on the road. Safer than a rigid delineator and clearly visible day and night, it has been designed for the safety of the most vulnerable road users.

Lightweight and resilient, the 48" Deflex delineator is made of a treated polymer blend to withstand harsh weather and vehicle impacts, and keeps its shape after as many as 200 impacts at 55 mph/88 km/h. 48" is the best height for being visible by all road users the bike Deflex 48 is a great traffic calming tool for the benefit of Vision Zero.

Made of flexible Polymer



Easy Installation on Multiple Surfaces



Clear and Safe Lane Marking



Increase Safety



Retractable Belt Delineator

Clear crowd channelizing is critical to holding successful public events and our DEFLEX crowd control delineator is the perfect tool to create passages and limit areas. With a height of 1200 mm (48"), variable installation options and quick installation, the Deflex delineator is the ideal tool to achieve efficient crowd control.



Made of flexible Polymer



Easy Installation



Manage Waiting Lines



Increase Safety



Road Works Delineators



Recommended colors

Our DEFLEX flexible channelizer delineator post for road work zones is a popular tool to control traffic when space is limited in areas where construction occurs. It stands four (4) feet tall and is notably thin in profile. It is made of a treated polymer blend that is flexible when struck by vehicles and resistant to bad weather.

The Deflex delineator is highly visible from all directions, day or night. It can be bolted in place or moved at will.

Day and Night Visibility



Easy Installation on standard posts



Increases Driver Awareness



Increase Safety



Lane Divider and Road Marking

Delimitation of the approaches to obstacles such as protrusions and bypass islands, and accentuation of road markings such as hatching at motorway entrances and exits and dangerous curves.

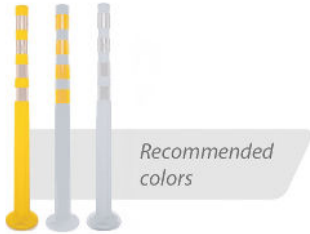

Increase Safety in Curves



Prevents Line Crossing



Improve Visibility



Visual Channelizing



The Deflex delineator post is made of a flexible polymer and regains its original shape even after more than 200 impacts. at 55 mph / 88 km/h with asphalt shield installation according to NTPED test Results you will achieve or exceed 200 impacts or more if installed as per this pattern.

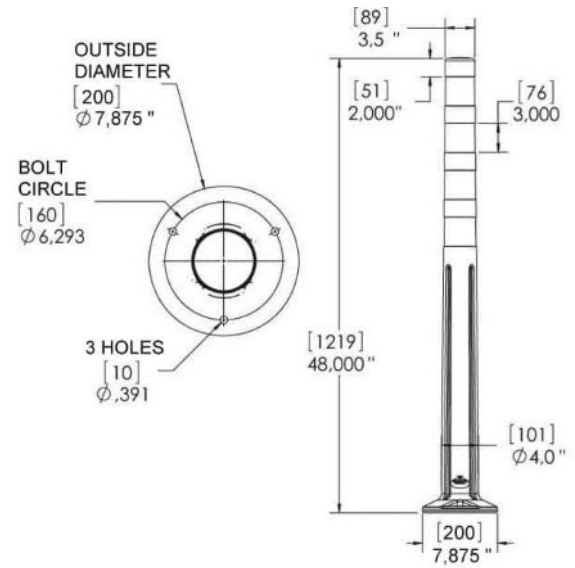
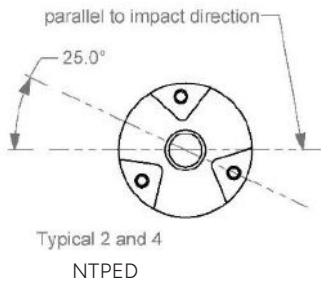

Suggested Spacing between delineators Bike Path

Speed Limit	Lane Divider <i>without</i> concrete lane path divider		Lane Divider <i>without</i> concrete lane path divider	
	Straight Lane	Curved Lane	Straight Lane	Curved Lane
20 KM/H / 30 KM/H	60' (20 m)	30' (10 m)	30' (10 m)	15' (5 m)
25 KM/H / 40 KM/H	60' (20 m)	30' (10 m)	30' (10 m)	15' (5 m)
30 KM/H / 50 KM/H	60' (20 m)	30' (10 m)	30' (10 m)	15' (5 m)

Center to Center Center to Center

Speed Limit	Roadwork and Lane Divider	
	Straight Lane	Curved Lane
20 KM/H / 30 KM/H	15' (5 m)	15' (5 m)
25 KM/H / 40 KM/H	15' (5 m)	15' (5 m)
30 KM/H / 50 KM/H	30' (10 m)	15' (5 m)
35 KM/H / 60 KM/H	30' (10 m)	15' (5 m)
40 KM/H / 70 KM/H	30' (10 m)	15' (5 m)
50 KM/H / 80 KM/H	45' (15 m)	15' (5 m)
55 KM/H / 90 KM/H	45' (15 m)	15' (5 m)
60 KM/H / 100 KM/H	60' (20 m)	15' (5 m)

Center to Center

How to Install

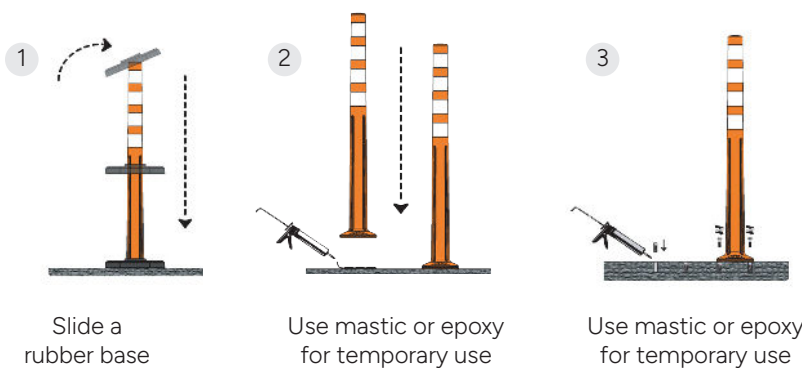

Installation Options

Mobile

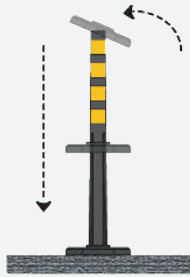

Slide a rubber base

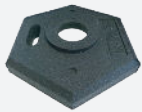

Weight of 16 lbs (7kg)
 Made of recycled rubber
 Ergonomic handle
 16" x 18,5" x 2,188"
 (406 x 470 x 56 mm)

Temporary

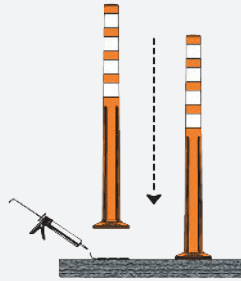

Use mastic or epoxy
 for temporary use



Sticky Mastic for asphalt
 or concrete.
 Steel plate included
 8" x 8" x 0,250"
 (203 x 203 x 6 mm)

Seasonal or permanent in asphalt

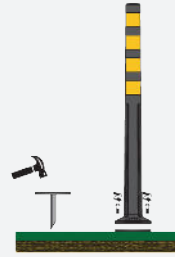

Use mastic or epoxy
 for temporary use



Galvanized steel
 ground spike
 8" x 8" x 16"
 (203 x 203 x 406 mm)

Seasonal or permanent in asphalt

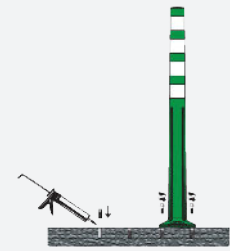

Use a drop of epoxy,
 shield and bolt



M10 Threaded shield
 for asphalt or concrete.
 Comes with 3 threaded
 caps to protect holes
 during the downtime

Permanent concrete border

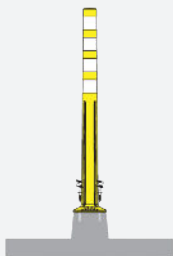

Bolt into a
 concrete border



3/8-16 x 2,5" zinc plated
 concrete screws for
 permanent installation

Permanent in concrete

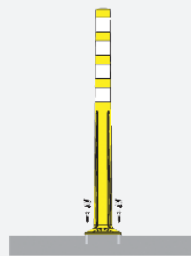

Bolt into
 concrete



3/8-16 x 2,5" zinc plated
 concrete screws for
 permanent installation

Easy-in, Easy-out

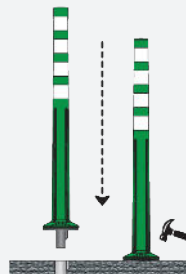

Insert the adapter
 into the sleeve



Steel Sleeve anchor
 8", 22" or 36" in length
 (200, 550 or 900 mm)
 (Carvelle System)



Need Help
 for installation?

info@traffic-innovation.com

Parts # to order DEFLEX system

1 Select Color

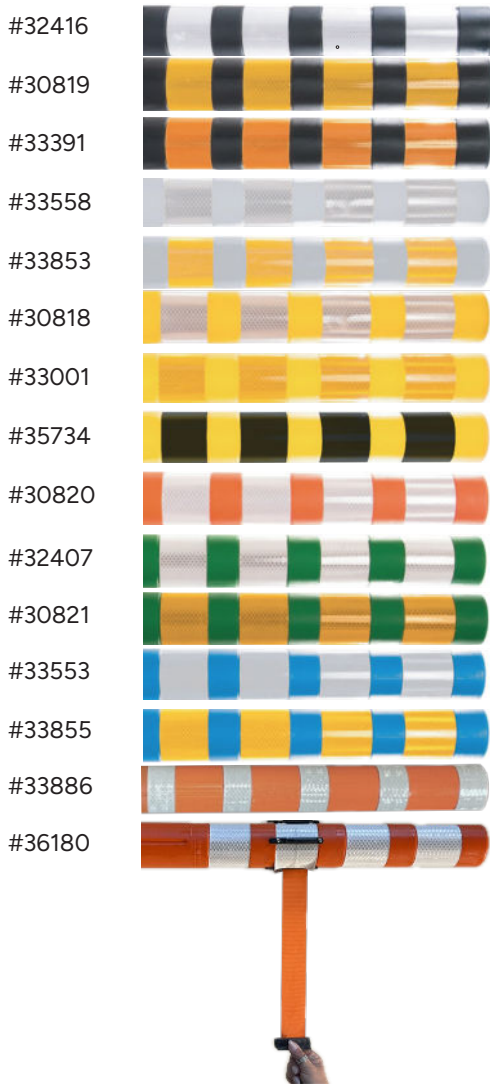

2 Add Accessories

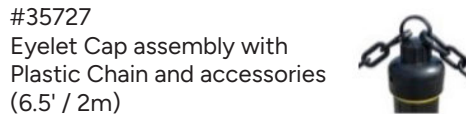
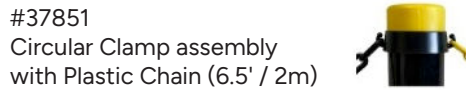
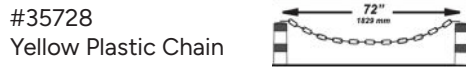

3 Installation Kit

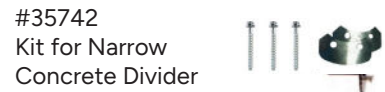
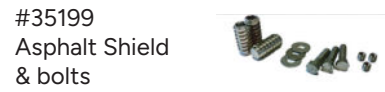
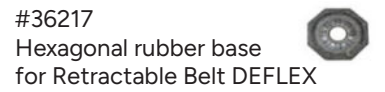

Minimum Order
50 units Pallet 42 x 46 x 26 in
1100 lbs

DECOFLEX, Flexible Decorative Bollard

Elegant and stylish, the DecoFlex flexible decorative bollard adds a touch of prestige in locations where flexible bollards are needed, namely curb extensions and sidewalk ledges, lane closure and even channelized lanes.

Made of flexible Polymer



Easy Installation



Several Tops Options



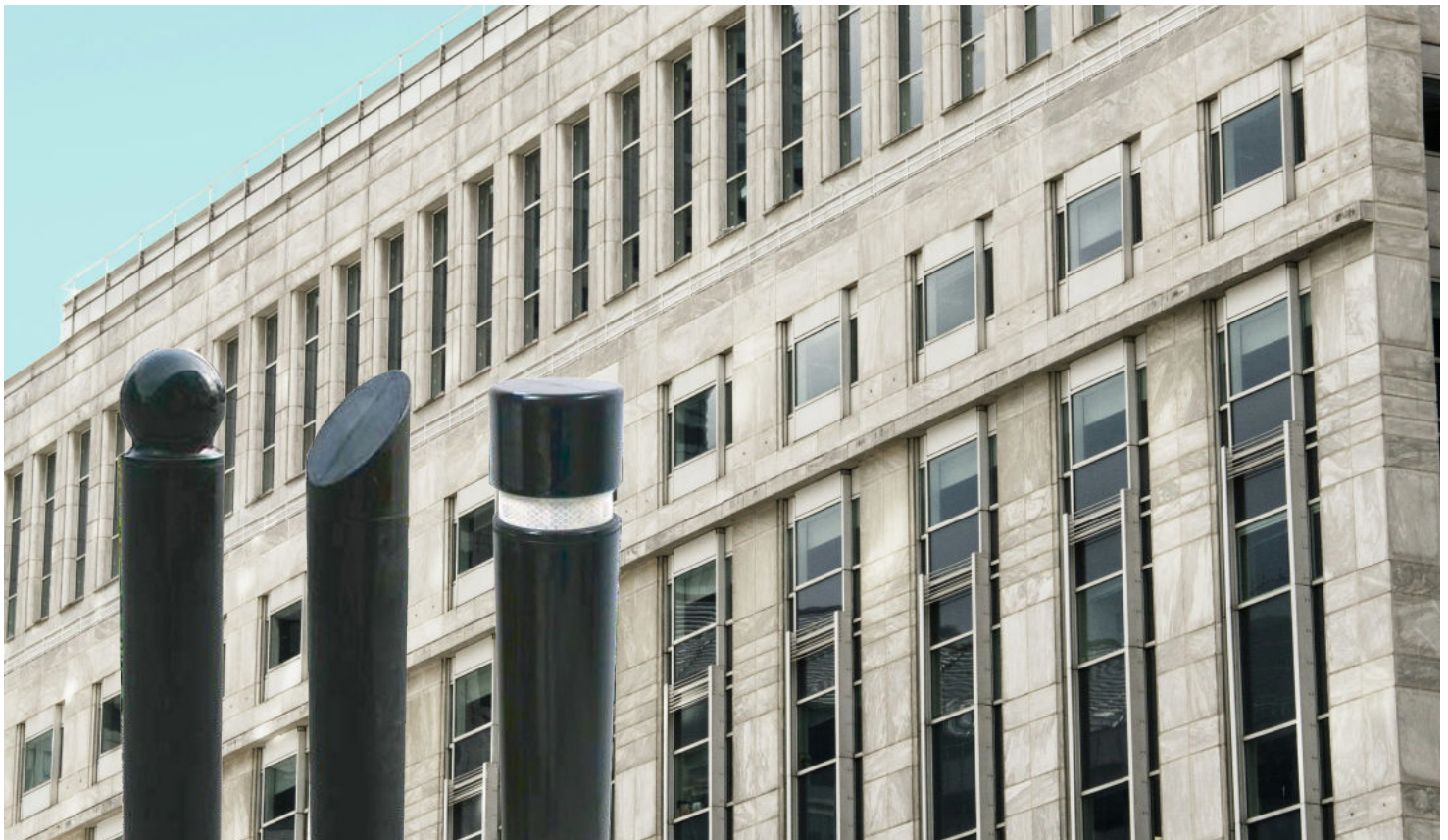

Increase Safety

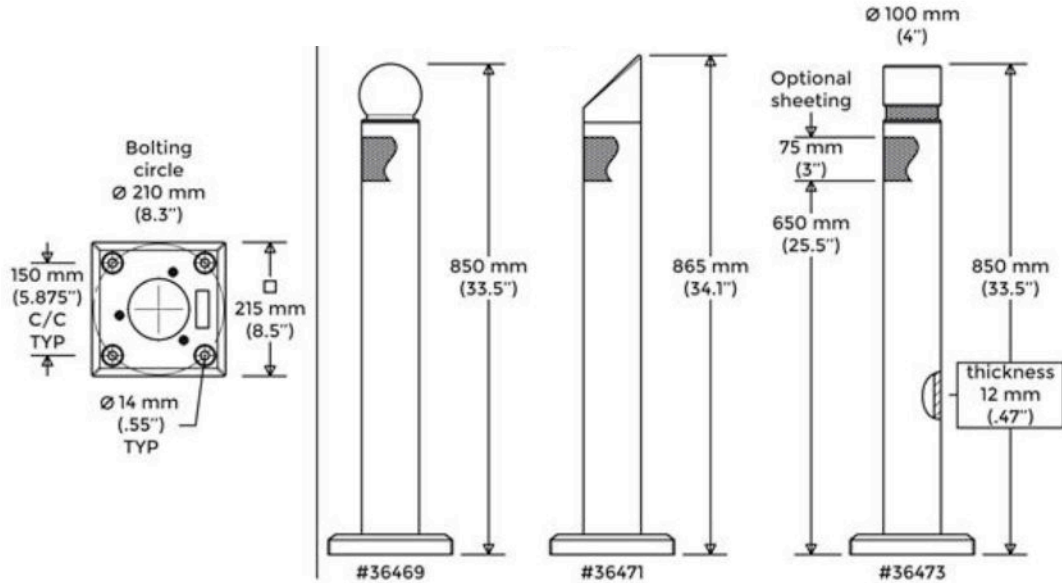

DECOFLEX Flexible Decorative Bollard



Products		Box Size - Weight	HSS Code
	Assembly Kit # 36469 100mm dia. x 34" BLACK DecoFlex Flexible Decorative Bollard, BALL Top c/w Square Base and Hardware 100mm dia. x 34"	Box of 5 units : 37 x 28 x 11 in – 450 lbs	3926.90
	Assembly Kit # 36471 100mm dia. x 34" BLACK DecoFlex Flexible Decorative Bollard, MITTERED Top c/w Square Base and Hardware 100mm dia. x 34"	Box of 5 units : 37 x 28 x 11 in – 450 lbs	3926.90
	Assembly Kit # 36473 100mm dia. x 34" BLACK DecoFlex Flexible Decorative Bollard, COLUMN/CYLINDRICAL Top c/w Square Base, Hardware 100mm dia. x 34" & White Reflective Sheeting	Box of 5 units : 37 x 28 x 11 in – 450 lbs	3926.90
	Options # 36879 DecoFlex CONCRETE Bolt-In Installation Kit	Box of 40 units : 11 x 17 x 4 in – 20 lbs	N/A
	Reflective Sheeting White #36542	N/A	N/A
	Reflective Sheeting Yellow #36543	N/A	N/A

BOPS-MC 5.5" Deco Steel Bollard

Often used in new layouts, the BOPS-MC protective safety steel bollard provides adequate protection for a sidewalk projection to ease traffic. From an aesthetic point of view, it is also used to delimit a zone reserved for pedestrians while remaining inaccessible to vehicles.

The safety bollard is installed in concrete (on a concrete sidewalk projection) to be installed with a 450 mm (17.7") steel carvel sleeve.

Improve
Visibility



Easy
Installation



Tough
and Sturdy



Increase
Safety

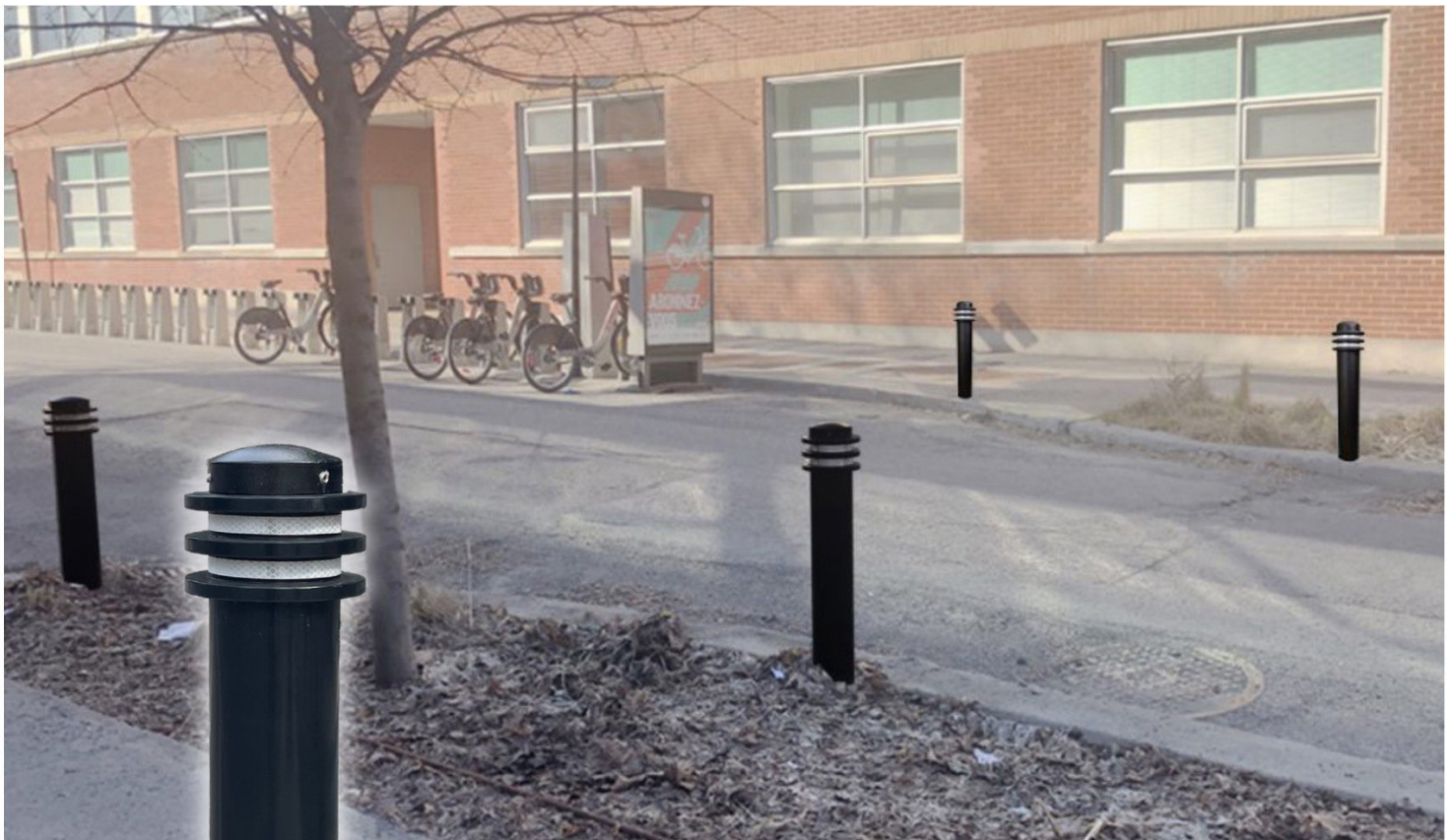

BOPS-MC 5.5" Deco Steel Bollard

2⁺
years
waranty

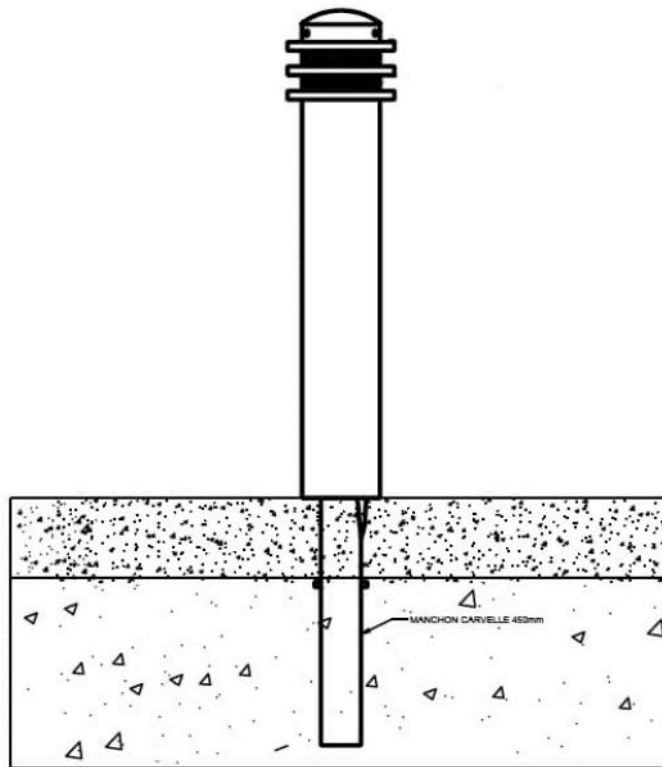

Products

Box Size - Weight

Assembly Kit # 36127
Decorative Bollard BOPS, 5.5" x 34" Steel, c/w Cap, painted textured black (Fixing system not included)

34 x 5.5 in – 63 lbs

Assembly Kit # 37482
Fixing system – Inner post for Carvel Sleeve Anchor

Call for info

Option # 30708
Track spike .375 X 3" steel

Call for info

Option
300 mm Carvel Sleeve Anchor

Call for info

Option
450 mm Carvel Sleeve Anchor

Call for info

BOC 6" Carvel Bollard

The 6-inch steel bollard with reflectors is a tough and sturdy visual marker to block traffic from forbidden areas. Made of powder-coated galvanized steel, the BOC648 has four (4) recessed reflective sheeting stripes that provide high visibility day and night.

Easy to install, it is inserted in the sleeve anchor (see the corresponding product page for details) and is as easily removed if needed, using the extractor tool. This 6" bollard is ideal for both temporary and permanent installation where vehicles are prohibited. Available in black with white or yellow reflective sheeting.

Blocks Vehicle
Access



Easy
Installation



Tough
and Sturdy



Increase
Safety



BOC 6" Carvel Bollard

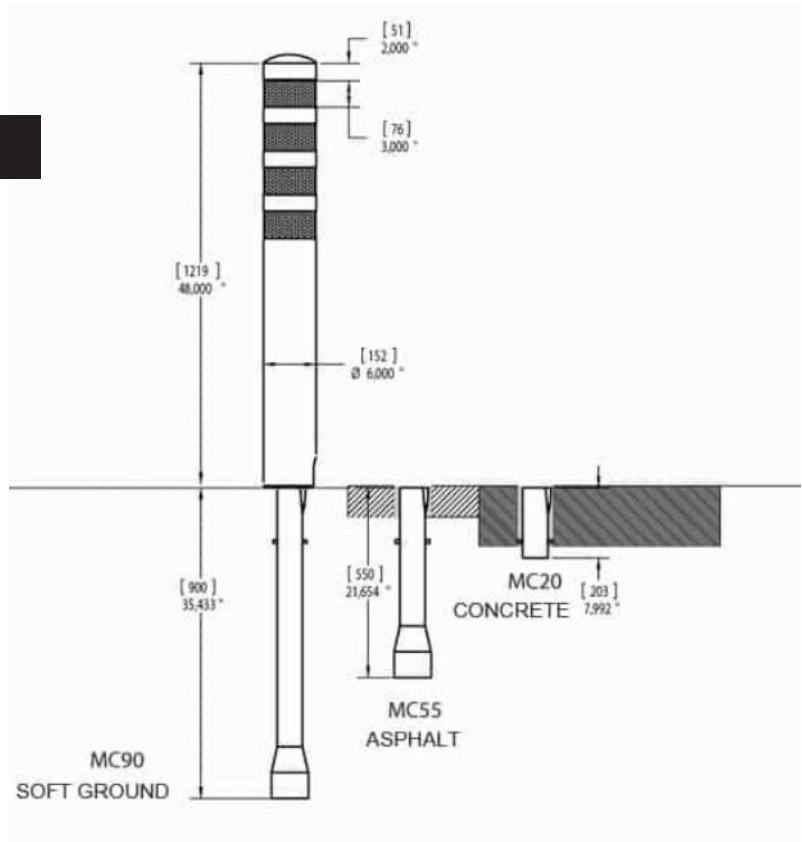

Features

Materials	Steel ASTM A500
Rust protection	Hot-dip galvanised
Finish	Powder coated painted
Color	Black
Reflective Stripe	3" White or Yellow ASTM Type IV
Height	48" (1220 mm)
Bollard diameter	6" (152 mm)
Weight	50 lbs (23 kg)



Products

Box Size - Weight

	<p>Assembly Kit # 30326 Carvel Bollard 6" (150mm) x 48" (1220mm) Galvanised Steel & Black painted c/w 4 White reflective bands</p>	6 x 48 in – 50 lbs
	<p>Assembly Kit # 30327 Carvel Bollard 6" (150mm) x 48" (1220mm) Galvanized Steel & Black painted c/w 4 Yellow reflective bands</p>	6 x 48 in – 50 lbs
	<p>Option # 30708 Track spike .375 X 3" steel</p>	Call for info
	<p>Option 200mm Carvel Sleeve Anchor (Concrete Installation)</p>	Call for info
	<p>Option 550mm Carvel Sleeve Anchor (Asphalt Installation)</p>	Call for info
	<p>Option 900mm Carvel Sleeve Anchor (Ground Installation)</p>	Call for info

Bike-CHSX Simple Bike Lane Chicane

Designed for cyclist safety near crossroads, the Bike-CHSX bike lane chicane makes an obstacle and creates a choking effect on the pathway, which together force cyclists to slow down. Made of powder-coated galvanized steel, chicanes are heavy duty, vandalism-proof and weatherproof.

Every chicane is equipped with a locking system that keeps it either in closed position or opened position for maintenance or emergency situations.

Improve
Visibility



Reduces
Speed



Open in case
of emergency



Increase
Safety



Chicane

Features

Materials Structure: Powder coated Galvanized Steel Sheeting: Diamond grade, type III

Standard colors Structure: Black, Textured Finish Sheeting: Yellow or White

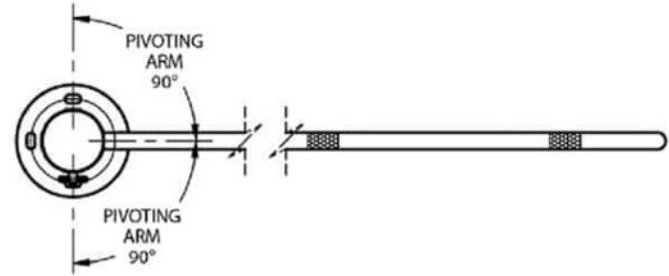

Products



Decorative Base dia. 150 x 280 mm #30689



Steel Buried Base Chemical Anchor dia. depth 1.4 m (55") #32371



Chemical Anchor dia. depth 1.4 M (55") #32371 3/4" X 9,6" #37596 (4)



Stainless Steel Padlock #37160

Visibility and safety on bike lanes

The reflective sheeting help locate the chicane in the dark. Installed near crossroads, the CHSX decorative chicane for bike paths effectively helps reduce speed and improves safety of every user.

Recommended Use

Bike path chicanes are in the first place intended to mark a potentially dangerous crossroad, then to make cyclists reduce their speed before actually crossing. The use of chicanes is recommended for all bike paths that are not directly on the side of the road. Besides, if the point is to block passage to cars and ATVs, it is recommended to install concrete bollards instead.

Recommended Installation

First of all, it's important to leave a minimum clearance space of 3 m before the crossroad. This is to allow cyclists to get off their bike. Secondly, keep units about 3 m apart. This is to facilitate the passage of kid trailer equipped bikes. Finally, leave a 1 m clearance width on the bike path, to create the aforementioned choking effect which will force cyclists to slow down before entering the chicane.

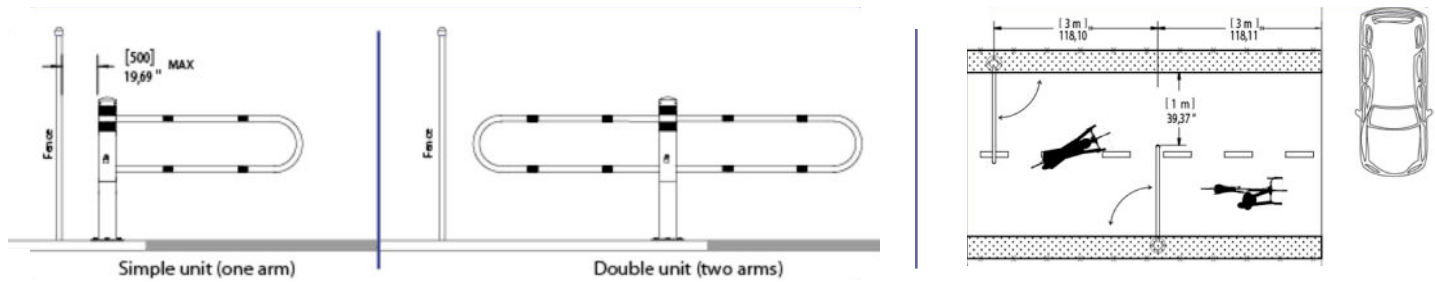

To avoid cyclists bypassing the chicanes, it is advised to install units near a fence or any kind of barrier by a maximum of 0,5 m. If the fence is too far away from the bike path or is simply non-existent, double units (with 2 arms) are to be used instead. They will fill the gap and prevent any possible bypassing.

Installation

Two methods can be used to secure units to the ground. If a concrete slab is already made, only four (4) chemical anchorings of dia. 3/4" x 9,6" are needed for installation.

For installations on asphalt or lawn, a concrete cylinder (sonotube-type) reinforced with a buried base will be needed for maximum strength. Just dig a cylinder of 305 mm (12") of diameter and 1524 mm (60") deep, pour in 30 MPa concrete and insert the buried base while keeping in mind the intended vertical orientation.

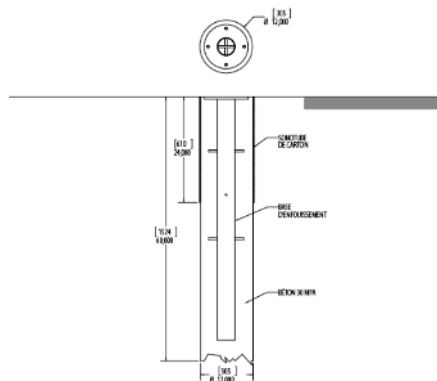

Products

Box Size - Weight



Assembly Kit # 37112 1,6 m Simple Steel Swivel barrier for Bike path
Black painted White or Yellow reflectives bands

Call for info

Assembly Kit # 37111 2,2 m Simple Steel Swivel barrier for Bike path
Black painted White or Yellow reflectives bands

Call for info

Assembly Kit # 37113 3,2 m Simple Steel Swivel barrier for Bike path
Black painted White or Yellow reflectives bands

Call for info



Assembly Kit # 38378 1,6 m Double Steel Swivel barrier for Bike path
Black painted White or Yellow reflectives bands

Call for info

Assembly Kit # 38268 2,2 m Double Steel Swivel barrier for Bike path
Black painted White or Yellow reflectives bands

Call for info

Assembly Kit # 38381 3,2 m Double Steel Swivel barrier for Bike path
Black painted White or Yellow reflectives bands

Call for info

Options



Option # 30690 Base cover, 6" x 12" painted black

Call for info



Option # 37160 Stainless Steel Padlock for barrier

Call for info



Option # 32371 48" deep Buried Base, Galvanised Steel c/w 4 Installation Bolts

Call for info



Option # 37596 Set of 4 Hilti .75 x 9.6" Stainless Steel Anchors with washers, nuts
HVU Epoxy Capsule & Installation Template

Call for info

Powered by



1 (866) 623-2580
traffic-innovation.com
info@traffic-innovation.com

February, 2025